

AN1603-433

Multilayer Chip Antenna for 433MHz Wireless Communication



AN1603 Multilayer Chip Antenna

◆ Features

- Light weight and low profile 16.0mm(L)X3.1mm(W)X1.65mm(H)
 - Omni-directional in azimuth
- Lead (Pb) Free

◆ Applications

- 433MHz wireless communications
- 433MHz Modules
- Other ISM band 420MHz~660MHz Wireless Application

Specifications

Center frequency	433MHz
Peak gain	0.5dBi
Operation temperature	-40 ~ +85 °C
Storage temperature	-40 ~ +85 °C
VSWR	2.0 (Max)
Input Impedance	50 Ohm
Power handling	3W (Max)
Bandwidth	8MHz
Azimuth beamwidth	Omni-directional
Polarization	Linear

Pin configuration



Pin No	Pin assignment
1	Feed termination
2	Feed point mark
3	Solder termination

Dimensions



Symbol	Dimensions (mm)
A	16.00±0.10
B	3.10±0.10
C	0.60±0.05
H	1.65±0.20

PCB foot printer

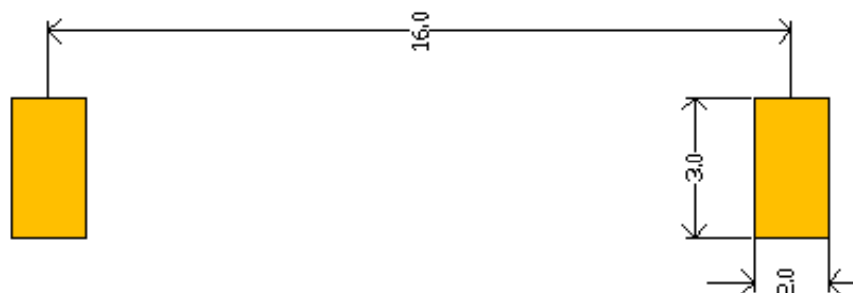

Recommended Test Board Pattern

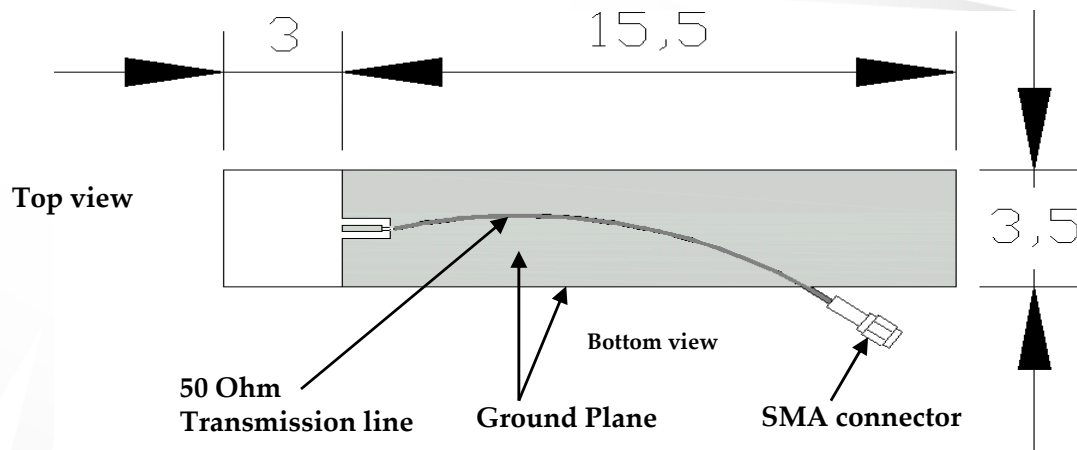

Unit : cm
 Board thickness : 0.6mm
 Board material : FR4

Fig-1

Testing Setup

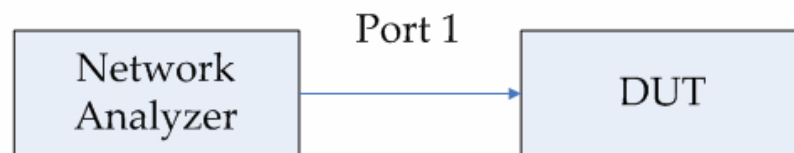

Measurement



Testing Instrument:

Anritsu 37369C VNA(Vector Network Analyzer)

VNA calibrate with 1 path reflection only calibration sequence on test board feed point.

The test board dimension and it's layout is the same as recommended Test Board.

Typical Electrical Characteristics

Return loss

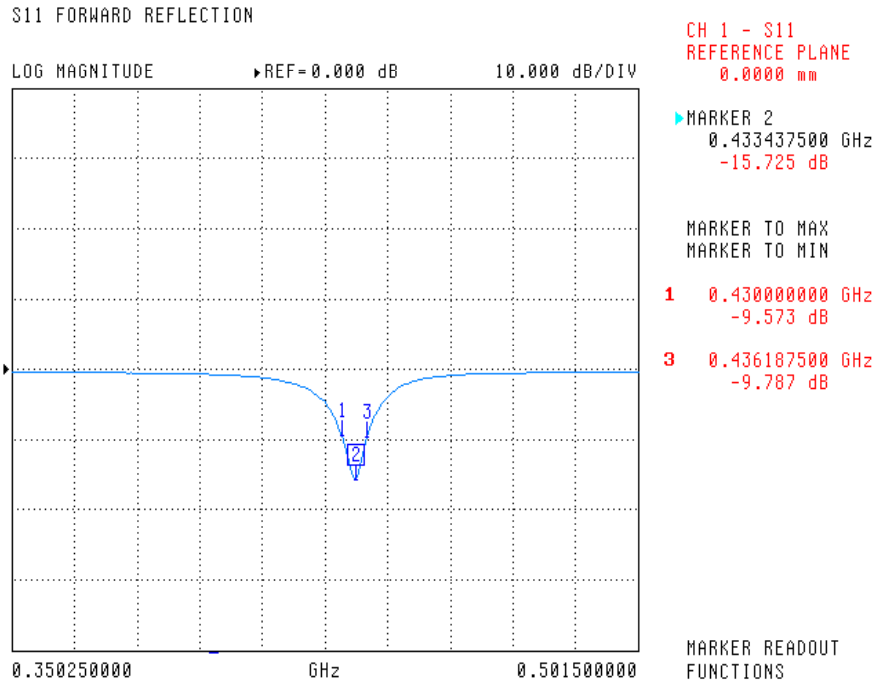

433 MHz Smith Chart

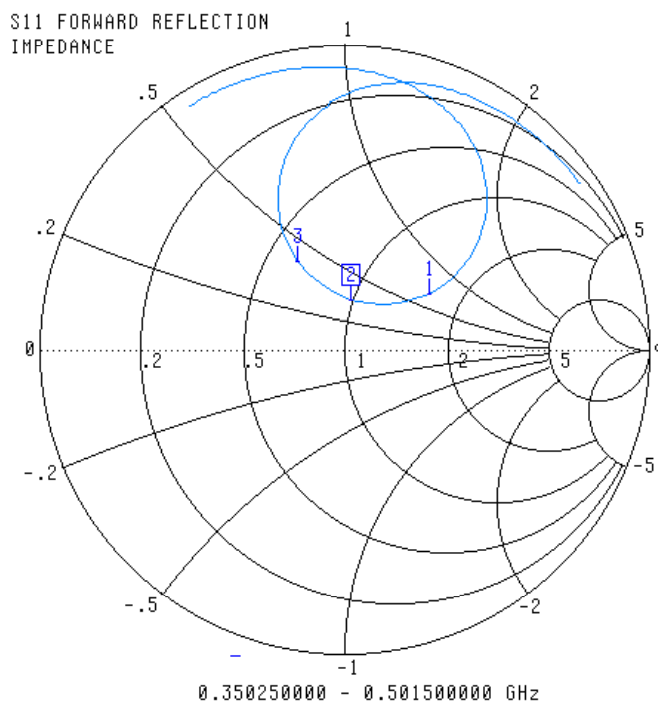

Marker data:

1 : f=430 MHz

2 : f=433 MHz

3 : f=436 MHz

3D Pattern

Theta

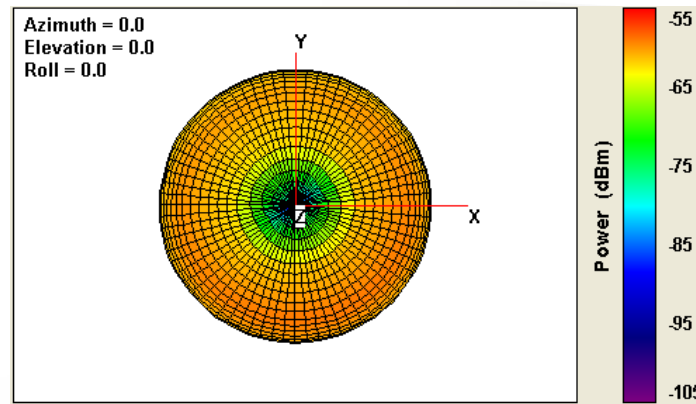

Free-Spec, 433 MHz

Phi

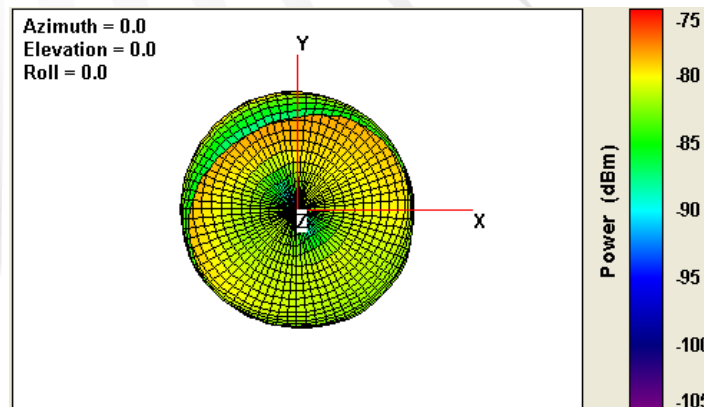

Free-Spec, 433 MHz

Total

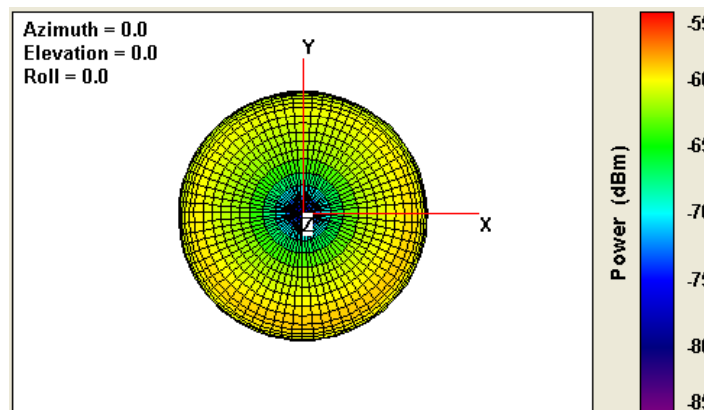

Free-Spec, 433 MHz

Typical Soldering Profile for Lead-free Process

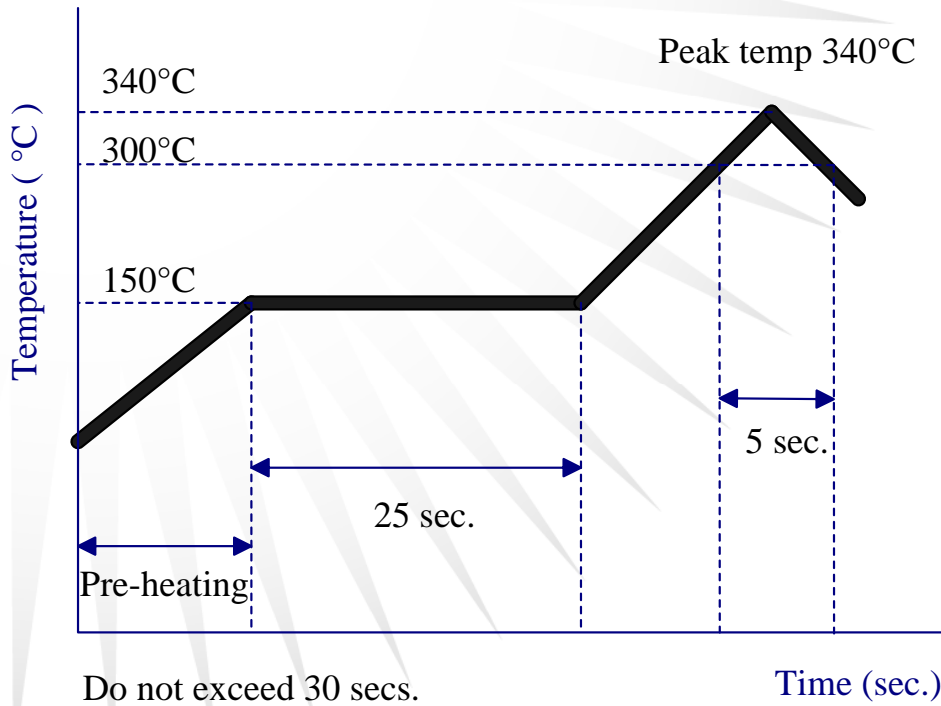

Reflow Soldering

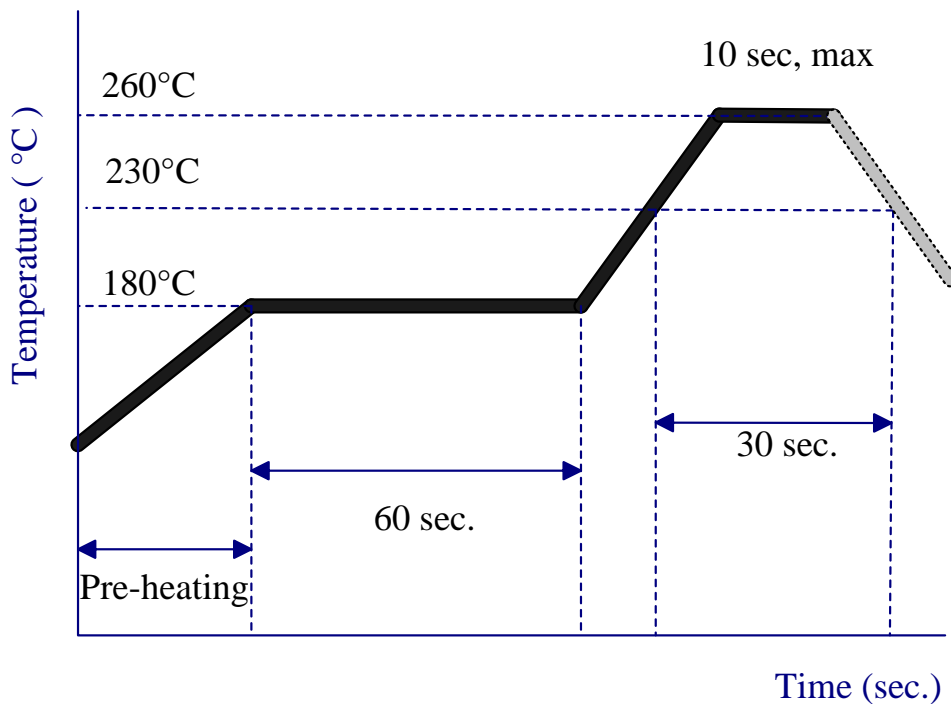

Packing

Blister Tape Specifications

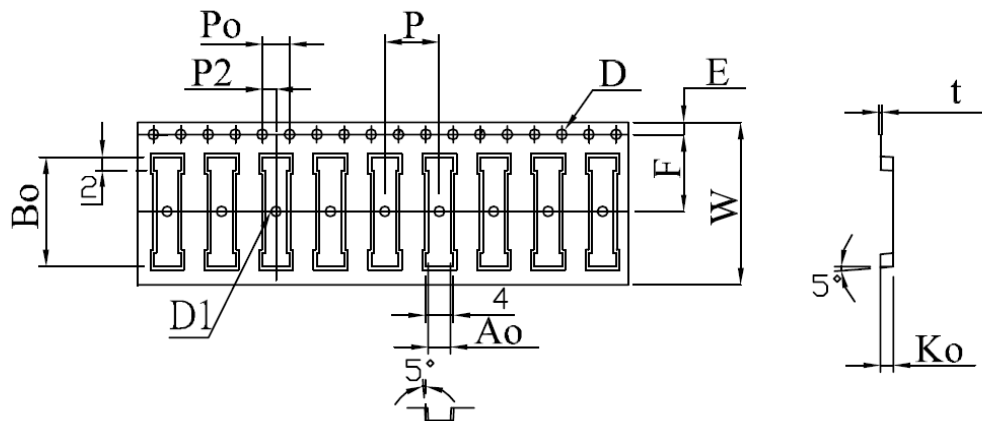

Symbol	Dimension	Tolerance	Unit
W	24.00	± 0.30	mm
P	8.00	± 0.10	mm
P2	2.00	± 0.10	mm
Ao	4.70	+ 0.10 - 3.20	mm
Bo	16.20	± 0.10	mm
Ko	1.90	± 0.10	mm
F	11.50	± 0.10	mm
E	1.75	± 0.10	mm
D	1.50	+ 0.10 - 0.00	mm
Po	4.00	± 0.10	mm
t	0.30	± 0.05	mm

Reel Specifications

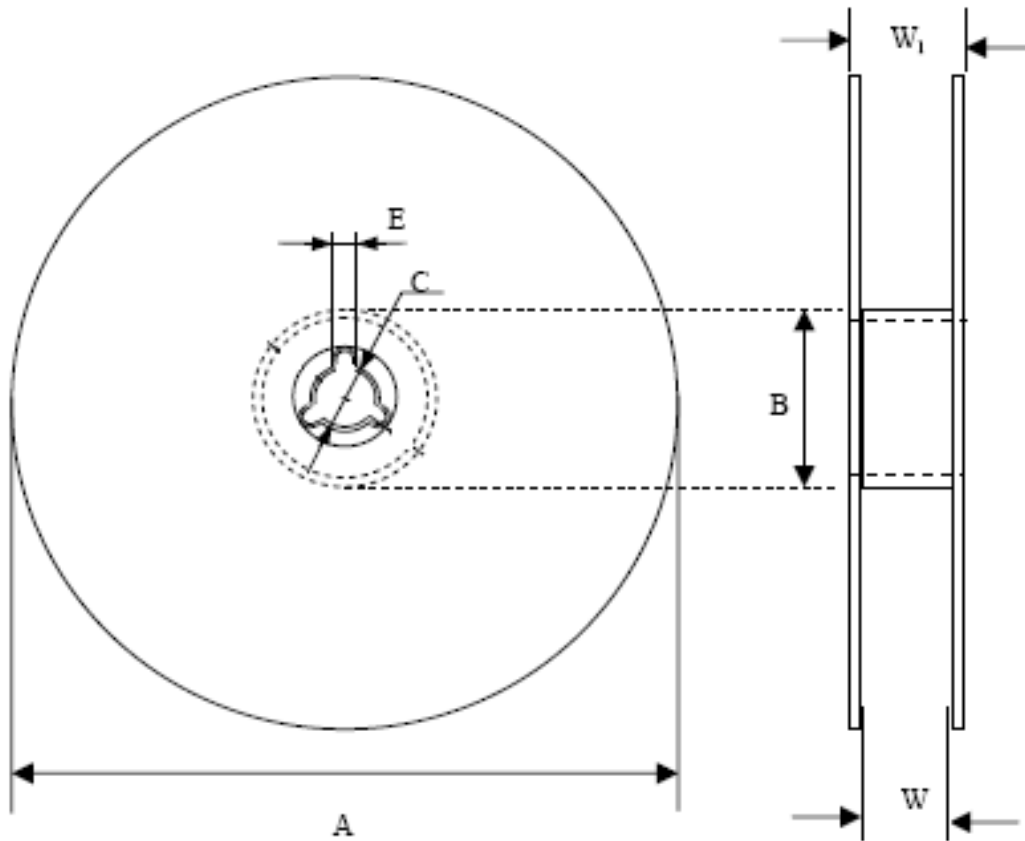

Quantity Per Reel	Tape Width (mm)	A (mm)	C (mm)	B (mm)	E (mm)	W (mm)	W_1 (mm)
3,000	24	330 ± 1	13.0 ± 0.5	100.0 ± 0.5	2.2 ± 0.5	24.0 ± 0.5	28.9 ± 0.2