

## 2.5W Class D Mono Audio Power Amplifier

### DESCRIPTION

The GSI8896A is a cost effective, low power, low EMI, mono, audio power amplifier. The GSI8896A delivers 2.5W into a 4 Ω load and offers efficiencies above 85%. The device utilizes Go2Silicon's proprietary ESF (EMI Suppression Function) technology and architecture. ESF circuitry greatly reduces EMI by controlling the edge rate of the output FET. Advanced dead zone control maintains state-of-the-art efficiency and THD+N performance. The output filter is eliminated and requires only three external components. The GSI8896A features high -70dB PSRR, as low as 0.04% THD+N, and 85dB SNR. Thermal protection prevents the devices from being damaged during over current conditions. Click and pop suppression circuitry is also built-in to eliminate click and pop noise.

### APPLICATIONS

- GPS
- MP3 MP4 Players
- Portable Computer
- PDAs

### APPLICATION CIRCUIT

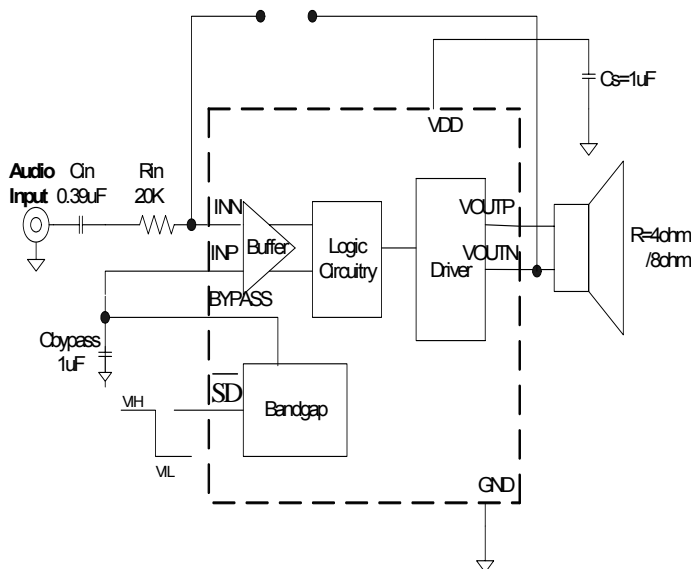

### FEATURES

- Filter less Capability
- Large Output Power Capability: 2.5 W into 4 Ω load
- Efficiency up to 85% at 400 mW
- Low Typical Quiescent Current 2.0 mA
- Low EMI Design with ESF technology
- Low Shutdown Current of 0.05 μA
- Wide Supply Voltage Range 2.5 V---5.5 V
- High PSRR at 217Hz (-70 dB)
- Compatible with single ended audio input signal
- Shutdown Pin is Compatible with 1.8V Logic
- Built-in Clock Generators
- Internal Thermal Shutdown
- Built in Click and Pop Suppression Circuitry
- Mini Small Outline Package (MSOP)
- RoHS Compliant, Lead free

### ORDERING INFORMATION

| Device   | TEMP Range      | PACKAGE    | TOP MARK |
|----------|-----------------|------------|----------|
| GSI8896A | -40 °C to 85 °C | 8 pin MSOP | LT       |

See detailed ordering and shipping information on page 7 of this data sheet.

Mini Small Outline Package (MSOP)  
(Top View)

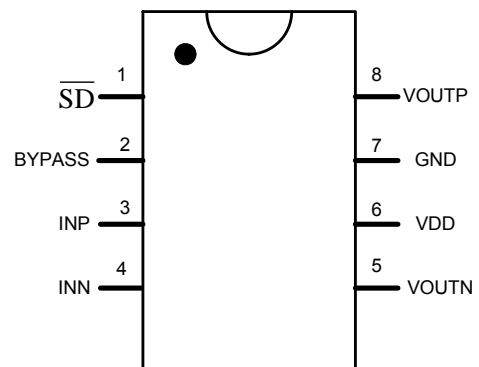

**PIN DESCRIPTION**

| Pin No. | Symbol          | Type | Description   |
|---------|-----------------|------|---|
| 1       | $\overline{SD}$ | I    | When $\overline{SD}$ is inserted, the device is entered into power down mode. |
| 2       | BYPASS          | I    | BYPASS pin  |
| 3       | INP             | I    | Positive Input  |
| 4       | INN             | I    | Negative Input  |
| 5       | VOUTN           | O    | Negative BTL Output   |
| 6       | VDD             | I    | Analog Power  |
| 7       | GND             | I    | Analog Ground   |
| 8       | VOUTP           | O    | Positive BTL Output   |

**MAXIMUM RATINGS**

| Symbol | Rating   | Max        | Unit    |
|--------|--|------------|---------|
| VDD    | Supply Voltage   | 5.5        | V       |
| Vin    | Input Voltage  | VDD+0.3    | V       |
| Tj     | Junction Temperature   | 150        | °C      |
| Ta     | Operating Ambient Temperature                                      | -40 to 85  | °C      |
|        | ESD Susceptibility<br>Human Body Model (HBM)<br>Machine Model (MM) | >2<br>>200 | kV<br>V |

**Recommended Operating Condition**

|                                      | Min | Max     | Unit |
|--------------------------------------|-----|---------|------|
| Supply Voltage, VDD                  | 2.5 | 5.5     | V    |
| High Level Input Voltage, VIH        | 1.5 | VDD     | V    |
| Low Level Input Voltage, VIL         | 0   | 0.4     | V    |
| Input Resistor, Rin                  |     | 20      | kΩ   |
| Input Capacitor, Cin                 |     | 0.39    | μF   |
| Bypass Capacitor, Cbypass            |     | 0.39    | μF   |
| Supply Decoupling Capacitor, Cs      | 1   |         | μF   |
| Common Mode Input Voltage Range, Vic | 0.5 | VDD-0.8 | V    |
| Operating Temperature                | -40 | 80      | °C   |

**Electrical Characteristic (Ta=25 °C, unless otherwise noted)**

| Symbol           | Characteristic                            | Conditions  | Min | Typ        | Max | Unit  |
|------------------|---|---|-----|------------|-----|-------|
| Vp               | Operating Supply Voltage                  | Ta=-40 °C to +85 °C   | 2.5 |            | 5.5 | V     |
| Idd              | Supply Quiescent Current                  | Vp=3.6 V, No Load<br>Vp=5.0 V, No Load                                |     | 1.5<br>2.0 |     | mA    |
| I <sub>sd</sub>  |   | Vp=2.5 V to 5.5 V<br>Ta=-40 °C to 85 °C                               |     | 0.02       | 0.1 | μA    |
| Z <sub>osd</sub> | Output impedance in shutdown mode         |   |     | 20         |     | kΩ    |
| R <sub>sd</sub>  | Resistance from $\overline{SD}$ to ground |   |     |            |     | kΩ    |
| V <sub>off</sub> | Output Offset Voltage                     |   |     |            | 10  | mV    |
| T <sub>on</sub>  | Turn on time                              | Vp=2.5 V to 5.5 V   |     | 10         |     | mS    |
| T <sub>off</sub> | Turn off time                             | Vp=2.5 V to 5.5 V   |     | 1          |     | mS    |
| T <sub>sd</sub>  | Thermal Shut Down Voltage                 | Vp=2.5 V to 5.5 V   |     | 150        |     | °C    |
| V <sub>on</sub>  | Output Noise Voltage                      | Vp=3.6 V, f=20 Hz to 20 kHz<br>No Weight Filter<br>With Weight Filter |     | 65<br>42   |     | μVrms |
| CMRR             | Common Mode Rejection Ratio               | Vp=2.5 V to 5.5 V<br>Vic=0.5 V to Vp-0.8 V<br>F=1.0 kHz               |     | -62        |     | dB    |
| PSRR             | Power Supply Rejection Ratio              | Vp-p ripple=200 mV, RI=8 Ω<br>Input AC grounded<br>F=1.0 kHz          |     | -68        |     | dB    |

**Electrical Characteristic ( $T_a=25\text{ }^\circ\text{C}$ , unless otherwise noted)**

| Symbol | Characteristic                    | Conditions  | Min | Typ                                  | Max | Unit |
|--------|-----------------------------------|---|-----|--------------------------------------|-----|------|
| Po     | RMS Output Power                  | RI=8 $\Omega$ , f=1.0 kHz, THD+N<1%                                   |     | 0.33<br>0.46<br>0.69<br>0.96<br>1.36 |     | W    |
|        |                                   | RI=8 $\Omega$ , f=1.0 kHz, THD+N<10%                                  |     | 0.4<br>0.6<br>0.88<br>1.20<br>1.70   |     | W    |
|        |                                   | RI=4 $\Omega$ , f=1.0 kHz THD+N<1%                                    |     | 0.48<br>0.71<br>1.05<br>1.62<br>2.12 |     | W    |
|        |                                   | RI=4 $\Omega$ , f=1.0 kHz, THD+N<10%                                  |     | 0.6<br>0.9<br>1.35<br>1.98<br>2.50   |     | W    |
| Ed     | Efficiency                        | RI=8.0 $\Omega$ , f=1kHz<br>Vp=3.6 V, Po=0.6 W<br>Vp=5.0 V, Po=1.2 W  |     | 84<br>85                             |     | %    |
|        |                                   | RI=4.0 $\Omega$ , f=1 kHz<br>Vp=3.6 V, Po=1.0 W<br>Vp=5.0 V, Po=2.0 W |     | 80<br>81                             |     | %    |
| THD+N  | Total Harmonic Distortion + Noise | Vp=3.6 V, RI=8 $\Omega$ ,<br>f=1.0 kHz, Po=0.25 W                     |     | 0.06                                 |     | %    |
|        |                                   | Vp=5.0 V, RI=8 $\Omega$<br>f=1.0 kHz, Po=0.25 W                       |     | 0.04                                 |     | %    |

## Application Information

### Component Selection

Table 1 shows the external components. Rin in conjunction with Cin creat a highpass filter.

$$C_{in} \geq \frac{1}{2\pi * 20K\Omega * 20Hz} = 0.397\mu F; \text{ use } 0.39\mu F$$

Figure 1 shows the GSI8896A typical schematic with single-ended inputs. Figure 2 shows the GSI8896A typical application circuit with differential inputs.

**Table 1. Typical Component Values**

| REF DES | VALUE      | VALUE               |
|---------|------------|---------------------|
| Rin     | 20KΩ       | 20kΩ (±0.5%)        |
| Cin     | 0.39μF     | 0.39μF (+22%, -80%) |
| Cbypass | 1μF        | 1μF(±10%)           |
| Cs      | 1μF        | 1μF                 |
| Rf      | Leave Open | Inf.                |

- (1) Ci is only needed for single-ended input or if Vicm is not between 0.5V and Vdd-0.8V.  
Rf is not needed, can just leave it open.

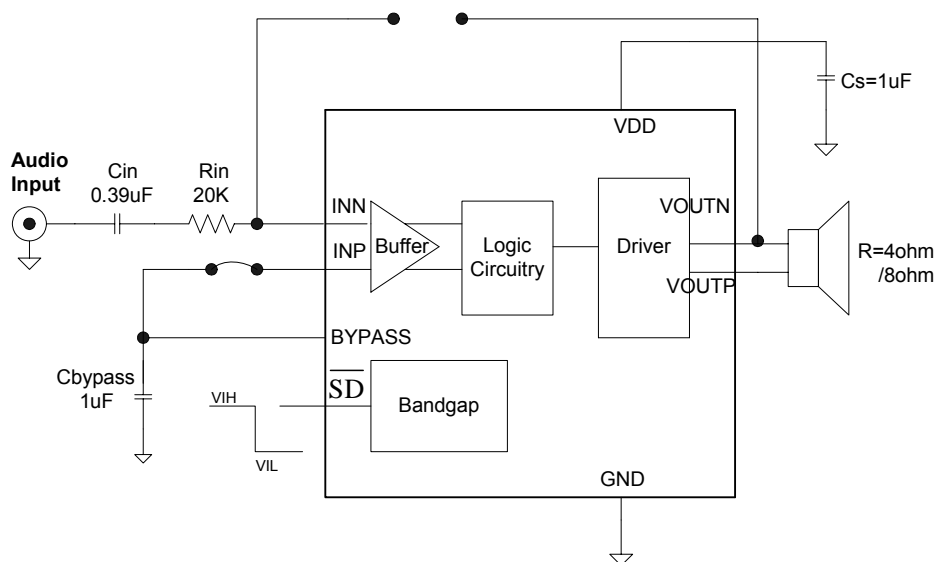

Figure 1. Typical Application Circuit Diagram for Single Ended Input

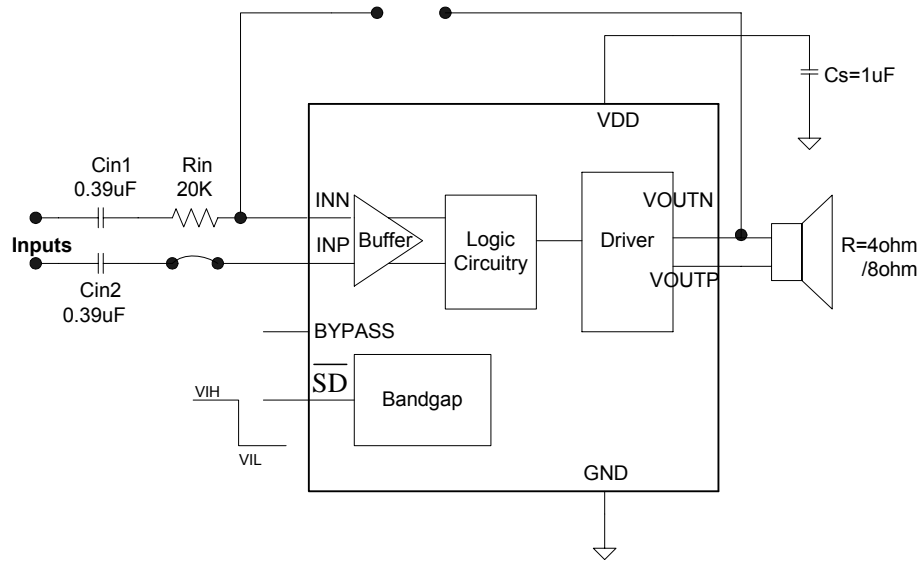

Figure 2. Typical Application Circuit Diagram for Differential Input

#### Decoupling Capacitor (Cs)

The GSI8896A requires adequate power supply decoupling to ensure the efficiency and low total harmonic distortion. A good low equivalent-series-resistance (ESR) ceramic capacitor, typically 1uF should be used. Placing this decoupling capacitor close to the GSI8896A is very importance for the efficiency of the amplifier.

**Ordering Information**

| Order Number | Package Type | Marking       | Shipping         | Operating Temperature Range |
|--------------|--------------|---------------|------------------|-----------------------------|
| GSI8896AMIT0 | 8 Pin MSOP   | 812a2<br>8896 | 3000/Tape & Reel | -40 °C to 85 °C             |

**GSI8896A** X X X X

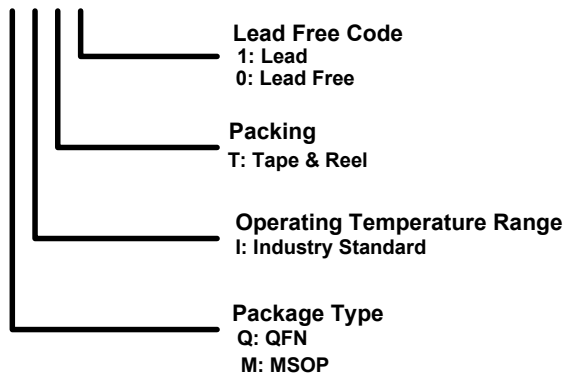

**Package Dimensions**

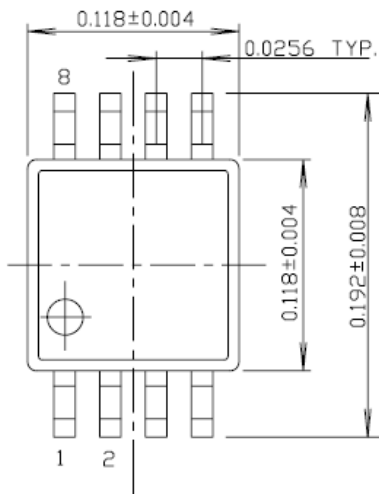

NOTE:

- 1) CONTROLLING DIMENSION: INCHES.
- 2) PACKAGE LENGTH DOES NOT INCLUDE MOLD FLASH, PROTRUSIONS OR GATE BURR.
- 3) PACKAGE WIDTH DOES NOT INCLUDE INTERLEAD FLASH OR PROTRUSIONS.

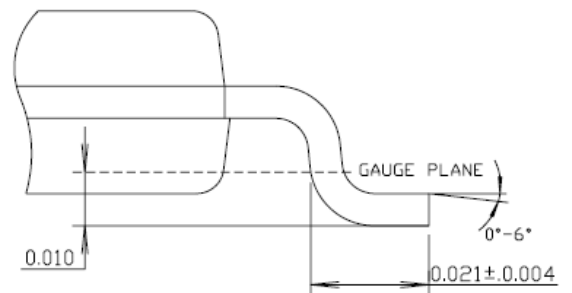

DETAIL "A"

